

## A.4 - PiC90 - CSM/CPU Central Service Module/Central Processing Unit

### Introduction

The CSM/CPU module for the PiC90 occupies the 1/2 slot in the rack.

The CSM/CPU converts AC power to regulated DC power. It supplies this power to the modules in the rack through the bus. The CSM/CPU controls the PiC90 system and executes the application program.

**Figure A4-1. PiC90 CSM/CPU Module**

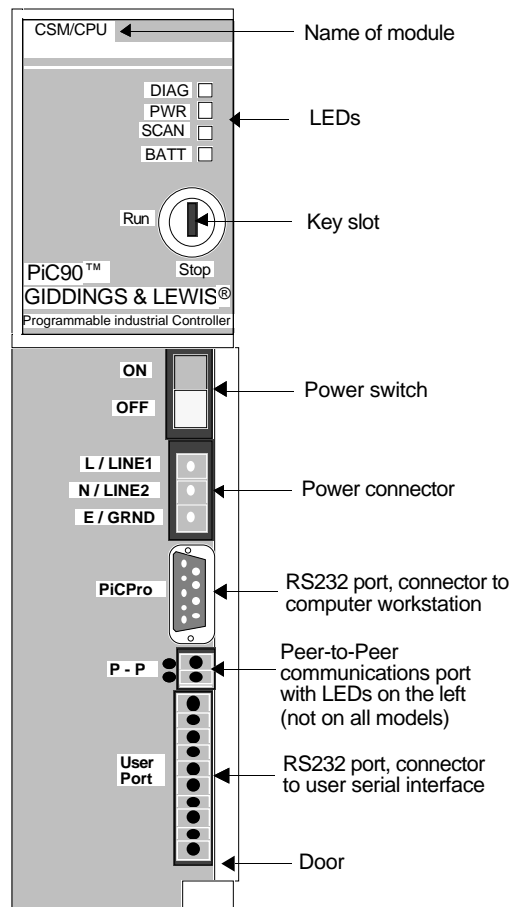

AG3-0493

## Connections

The CSM/CPU module receives power through a 3-pin power connector. Figure A4-2 illustrates the connections as listed below.

Module	AC Power Source
L / LINE 1	to Hot
N / LINE 2	to Common
E / GRND	to Single Point Ground

**Figure A4-2. AC Power to the System**

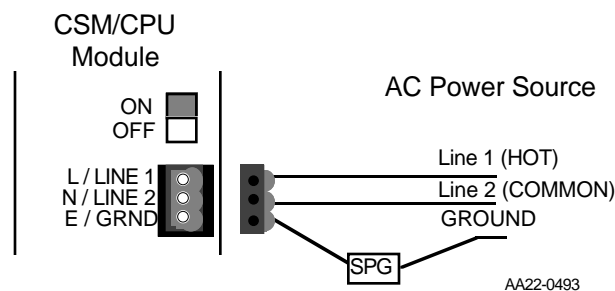

## Serial Ports

The PiCPro Port (9-pin D connector) communicates with the workstation serial port and the User Port (10-pin screw terminal connector) communicates with an optional serial interface device.

**Figure A4-3. Pinouts for the Two RS232 Communications Ports**

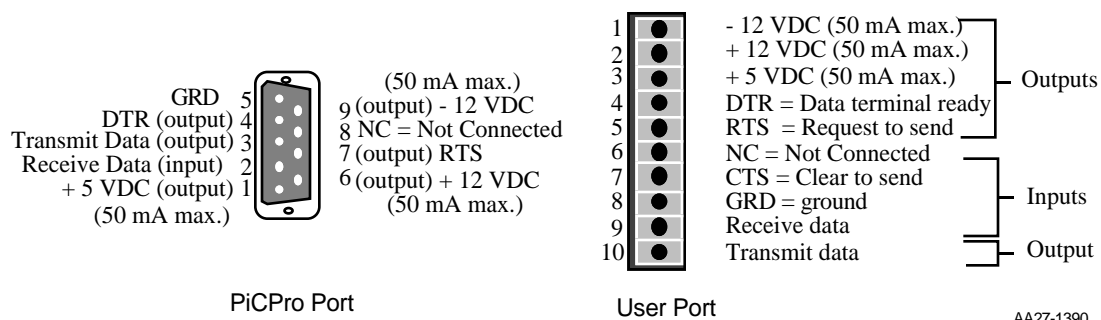

The PiCPro Port allows the PiC90 to communicate with the workstation. This port is used when downloading an application program from the workstation into RAM memory. It may also be used to exchange data between the workstation and the PiC90 system while the PiC90 system is running.

The pinout for the PiCPro Port cable is shown below.

**PiCPro Cable Pinout**

<b>9-pin female (to PC)</b>		<b>9-pin female (to PiCPro Port)</b>
3	to	RD 2
2	to	TD 3
5	to	GND 5

NOTE: Other pins may be connected in the cable received from Giddings & Lewis, but only pins 2, 3, and 5 are used.

The User Port is used to communicate with a touch-screen, a hand-held controller, or other serial interface device.

**Peer-to-Peer (ARCNET) Communications Port (Optional)**

Two versions of the CSM/CPU module offer the ability for peer-to-peer communications from one PiC90 to another (or to PiC900s). The location of the peer-to-peer communication port is shown in Figure A4-1.

**Figure A4-4. Pinout for the Peer-to-Peer (ARCNET) Communications Port**

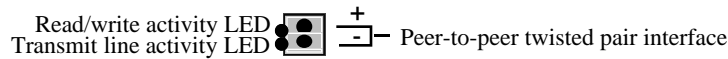

<b>CAUTION</b>
The network is polarity dependent. Always connect the positive (+) of the twisted pair interface of the first PiC to the positive (+) of the twisted pair interface of the second PiC and the negative (-) to the negative (-), etc.

Refer to Appendix N Peer-to-Peer Communications for information on connecting PiCs on a network.

## LEDs

### Status LEDs

The CSM/CPU module has four LEDs to indicate status as shown in Figure A4-1. They are described below.

NOTE: During normal operation the DIAG and BATT LEDs should be off, and the PWR and SCAN LEDs should be on.

<b>Diagnostic (DIAG)</b>	
ON	The CPU is running diagnostic tests on all modules at power up.
OFF	Normal operation
Flashing	Flashes error codes under certain conditions. These codes are listed in Appendix M.
<b>Power (PWR)</b>	
ON	Power is on to the system. It indicates that the +5V supply is within tolerance. See the specification sheet.
OFF	No power to the system
<b>Scan</b>	
ON	The processor is executing the application program.
OFF	Scan is lost and there is an orderly shut down procedure followed.
<b>Battery (BATT)</b>	
ON	Goes on briefly while the battery is checked at power-on.
OFF	Battery passed power up test.
Flashing	Replace lithium battery. See replacement procedure that follows.

### Communication LEDs

For the PiC90s with the optional communication port, there are two LEDs located to the left of the two-pin connector. Their status is described below.

LED	Status	Description
Peer-to-peer read/write activity	Flash/on	Data being transferred to/from CSM/CPU
	Off	No data transfer
Peer-to-peer transmit line activity	On	Normal network activity
	Blinking	Network reconfiguration
	Off	Not active part of network

## **CSM/CPU Time-of-Day Clock**

---

An internal clock IC maintains the current date and time. If power is off to the system, the battery maintains the clock. The application program and PiCPro can access this clock. Details are given in the Software manual.

## **Theory of Operation**

---

The CSM/CPU module converts AC input power into DC power at voltages of + 5V, + 15 V, and - 15 V and supplies them to the logic side of the modules in the rack. External power supplies are used for the field side of the I/O modules. Such supplies are not routed through the CSM/CPU, but they should all have the same power cut-off switch as the PiC90. See the power distribution diagrams in the Hardware chapter.

### **CAUTION**

The on/off rocker switch on the face of the CSM/CPU does not control the I/O power supplies.

Always shut off power at the main disconnect switch before you replace a module in the system rack.

With the CSM/CPU module, a key is supplied to protect the system from unauthorized start-ups. You can set up the PiC90 hardware, power up and run the diagnostic tests, and even load a software application program without the system key. However, the application program will not be scanned until you turn the Run/Stop key on the CSM/CPU to the Run position.

The CSM/CPU module does the following:

- Performs diagnostic tests.
- Checks the battery.
- Performs routine maintenance tasks.
- Executes the application program.
- Communicates with the I/O modules.
- Maintains communication with the workstation through the PiCPro port.
- Maintains communication with the user interface device through the user port.\*
- Details for this communication depend partly on the type of interface device. Refer to the manual that comes with the device.

## **Replacing the Battery on the CSM/CPU**

---

Follow the procedure below to replace a battery.

1. After AC power has been applied to the CSM/CPU for at least five minutes, turn off power at the control cabinet main disconnect switch and at the CSM/CPU power switch. Unplug all connectors from the CSM/CPU.
2. Remove the CSM/CPU module from the rack by pressing down the latch at the top and pulling it out.
3. Use a static-free work surface if possible. Ground yourself using a properly grounded wrist strap before you open the case. These are standard precautions before handling any electronics component.
4. Lay the CSM/CPU on the work surface with its label side up. Press the plastic tabs at the top and bottom of the module case toward each other and lift the side cover off

<b>WARNING</b>
Do not touch any of the capacitors. Do not touch the pins on any of the ICs; even with precautions against static you may destroy the circuitry.

5. Use Figure A4-5 to locate the battery. Note how it is oriented.

Figure A4-5. Inside the CSM/CPU Module: Position of Battery

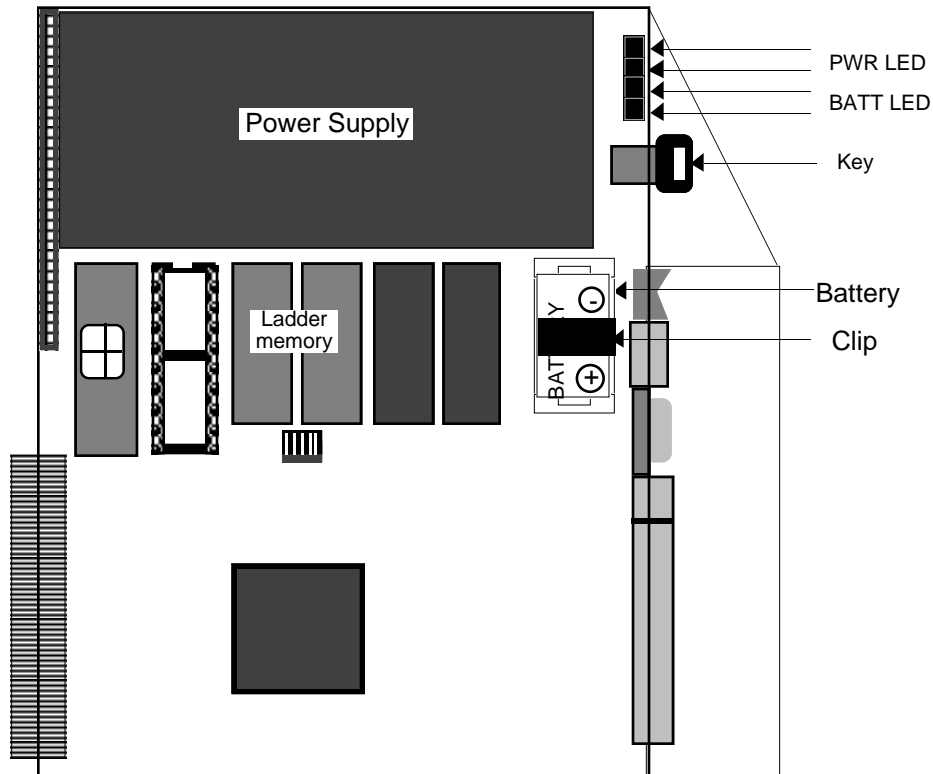

6. Use an insulated screwdriver to pry out one end of the battery clip. Remove the clip. Lift the battery out. Replace it with a 3V, 2/3A lithium battery. (See the specification sheet at the end of this section.) Replace the clip ensuring that it is latched.
7. Close the case and insert the CSM/CPU in the rack. Reconnect all the cables. Turn on power and check the LEDs.

### Additional Integrated Circuits (ICs) for the PiC90

---

You may need additional ICs to run your application program.

**EPROMs.** An application may be programmed into a pair of EPROMs, and then the EPROMs may be inserted in the CSM/CPU module. Recommended EPROMs include:

#### **For Standard CSM/CPUs**

Advanced Micro Devices (AMD) AM27C010-200DC (128K x 8)

#### **For Turbo CSM/CPUs**

Advanced Micro Devices (AMD) AM27C010-120DC (128K x 8)

The Software manual gives directions for creating a file in a format suitable for an EPROM. This file may be loaded from a workstation into the EPROMs using any

of a number of commercially available EPROM Programmers. The file originates at address zero and, therefore, requires no offset. The file uses the 16-bit word format. Your programmer must have the capability of programming even addressed information into one 8-bit device and odd addressed information into another 8-bit device.

**Math coprocessor** (optional) Some applications may require a math coprocessor. The socket for this IC is next to the memory ICs. See Appendix K for the installation procedure.

### Procedure for Installing EPROMs into LAD MEM

Figure A4-6 shows the locations of the ladder memory ICs.

**Figure A4-6. Ladder memory location**

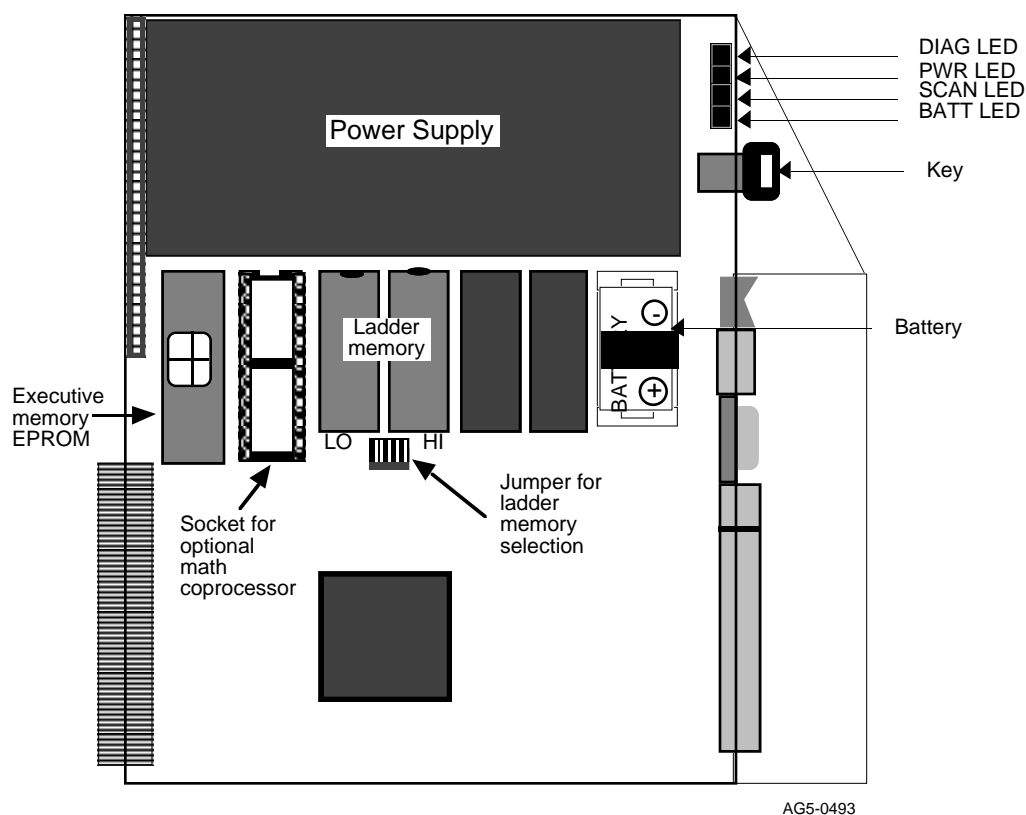

Follow the procedure below to install EPROMs in the LAD MEM sockets.

1. Lay the CSM/CPU module on a static-free surface, label side up. Ground yourself using a properly grounded wrist strap before you open the module. These are standard precautions before handling any electronic components.
2. Press the plastic tabs at the top and bottom of the module toward each other and lift off the module cover.

**CAUTION**

Do not touch the pins on any of the ICs. IC circuitry can be easily damaged. Broken or bent pins prevent the IC from functioning properly.

3. Use Figure A4-6 to see where the ICs should be placed. If a pair of ICs occupies the sockets already, use an IC-removal tool to remove them.
4. To insert a new pair of ICs, start with the one labeled LO. Use an insertion tool to position it over the left LAD MEM socket labeled LO with the notched end of the IC matching the notched end of the socket. Line up the pins and push it in place. Repeat with the HI IC in the right socket of the pair.

**CAUTION**

Check that the IC is going in the correct socket. The processor cannot access an IC in the wrong place.

Make sure the IC is oriented correctly. If it is installed backwards, it may be destroyed when power is turned on to the system.

5. Place the jumper in the correct position for the type of IC (EPROM or RAM) you are inserting. (See Figure A4-6 for jumper location.)
6. Replace the module cover. Insert the CSM/CPU module in the rack. Connect all the cables. Turn on power at the main disconnect switch and the CSM/CPU power switch. Check the LEDs.

Specification Table

Characteristic		CSM/CPU specifications									
Functions		Supplies regulated DC power to the hardware modules installed in the rack. Executes the application program. Executes Diagnostics on the system and its modules. Communicates through the RS232 ports to external devices. Option: Peer-to-peer communication with PiC900 family of controls									
<b>Models available</b>							Number of servo axes available at six update rates*				
PiC90 Model	Part Number	Speed	App Mem	RAM Mem	User Mem	8 ms	4 ms	2 ms	1 ms	.5 ms	.25 ms
Standard	502-03846-03	8 MHz	128K	64K	32K	6	4	2	1	0	0
Standard w/Peer-to-Peer	502-03846-23	8 MHz	128K	64K	32K	6	4	2	1	0	0
Turbo	502-03853-03	16 MHz	256K	128K	32K	6	6	4	2	1	0
Turbo w/Peer-to-Peer	502-03853-23	16 MHz	256K	128K	32K	6	6	4	2	1	0

\*The number of axes listed is typical for RATIO\_GR, RATIOCAM, VEL\_STRT, POSITION and DISTANCE move types. Applications which use time axes, servo tasks, RATIO\_RL, M\_LINCIR, or M\_SCRVLC moves require more CPU time. Consult Giddings & Lewis for assistance if you want to exceed the number of axes in this chart.

AC power source	90-250 VAC, 47-440 Hz, 1A
DC power source	20 -36V DC, 3 A
Part numbers	Standard      Standard w p-to-p      Turbo      Turbo w p-to-p 502-04035-00    502-04035-20    502-04036-00    502-04036-20
Input connector	3-terminal plug connector, meets all specifications for touch safety in accordance with IEC 529 and DIN VDE 0470 part 1
Power output, total	CSM/CPU 40 W
Individual outputs	+ 5 V @ 5.0 A + 15 V @ 2.0 A -15 V @ .5 A
Battery	1.2 Ah 3V, 2/3A lithium battery

**PiC90 - CSM/CPU Central Service Module/Central Processing Unit**

+ 5 V supply monitor	Low trip point 4.50V min 4.75V max High trip point 5.50V min 5.94V max PWR LED goes off and PiC90 shuts down
Flash memory system board (optional)	4 Megabyte FMS Board 502-03882-00 8 Megabyte FMS Board 502-03882-20
Math coprocessor (optional)	Numeric coprocessor Part Number 401-54187-10
PiCPro port (to work-station)	RS232 serial port, secured protocol Software selectable baud rate (300 to 57600 baud)
User port (to serial interface device)	RS232 serial port Supports RTS/CTS hardware handshaking Baud rates to 19.2 K
Peer-to-peer communications  Port available on 502-03846-20 and 502-03846-40 models	Allows for communication between PiC90s and/or PiC900s (up to 255)  A dedicated network controller supports peer-to-peer communications. Provides a twisted pair wire interface that is transformer isolated. Data is transferred serially at a rate of 2.5 megabits per second.
Twisted pair wire	24 or 26 AWG solid or 26 AWG stranded  <b>IMPORTANT</b> Use of other wire sizes may result in an impedance mismatch that could disable communications with some or all nodes on a network when doing peer-to-peer communications.
Time-of-day clock	Access via PiCPro or application program.
Clock tolerance	At 25° C, ±1 second per day Over temperature, voltage and aging variation, +2/-12 seconds per day
Logic side power requirements (typical)	340 mA @ +5V (502-03846-03)* 440 mA @ +5V (502-03846-23)* 430 mA @ +5V (502-03853-03)* 530 mA @ +5V (502-03853-23peer) 50 mA @ -15V (with peer-to-peer) 5 µA @ +3V (all)**  *Add 110 mA at +5V when math coprocessor is installed. **From the battery during power down.
Operating temperature range	7° C to 55° C (45° F to 131° F)
Storage temperature range	-40° C to 85° C (-40° F to 185° F)

**PiC90 - CSM/CPU Central Service Module/Central Processing Unit**

Humidity	0 to 95%, non-condensing
EMC Compliant Emissions Noise immunity	Operates with emissions below EN55011/ CISPR 11 Class A limits Immune to: <ul style="list-style-type: none"><li>• Electrostatic discharge (4K V contact mode, 8K V air discharge) per IEC1000-4-2</li><li>• RF electromagnetic fields per IEC 1000-4-3</li><li>• Electrical fast transients per IEC 1000-4-4 on incoming power lines</li></ul> Refer to the EMC Guidelines for more information.
UL and C/UL Listed	File No. E126417 NRAQ Programmable Controllers
Physical size	2.4" wide x 12" high x 8.4" deep (including latch) 61 mm x 305 mm x 213 mm