

## **Return or Disposal of Motors**

Please contact the source that supplied the motor should warranty or non-warranty repair be required. All returned products require a Return Material Authorization (RMA) number for efficient processing and tracking.

Motors do not contain hazardous substances. A motor may be disposed of as mechanical scrap, or you may return an environmentally clean motor at your cost for disposal by us.

## **Technical Support**

In the United States, hours for product assistance are 7:00 AM to 5:00 PM (CST), Monday through Friday at 1-800-558-4808 or via fax at 1-920-906-7669.

In Europe, product assistance can be obtained between 8:30 and 17:30 local time, Monday through Friday at (+44)151-546-2010 or via fax at (+44)151-547-2801.

# **HSM Series Brushless Servo Motor Manual**

# Product Notice

## Use of Motors

Servo motors are intended to drive machinery. As such, they must be part of a controlled system that includes a transistorized electronic amplifier. They are not intended for direct connection to the power supply or for use with thyristor drives. Instructions in the amplifier and control system manuals must be observed; this document does not replace those instructions.

Unless specified otherwise, servo motors are intended for use in a normal industrial environment without exposure to excessive or corrosive moisture or abnormal ambient temperatures. The exact operating conditions may be established by referring to the data for the motor. The mating of motors to machinery is a skilled operation; disassembly or repair must not be attempted. In the event that a motor fails to operate correctly, contact the place of purchase for return instructions.

## Safety Notes

There are some possible hazards associated with the use of motors. The following precautions should be observed. Specific Warnings and Cautions are listed inside the back cover.

**Installation and Maintenance:** Installation and maintenance or replacement must be carried out by suitably qualified service personnel, paying particular attention to possible electrical and mechanical hazards.

**Weight:** Large motors are generally heavy, and the center of gravity may be offset. When handling, take appropriate precautions and use suitable lifting equipment. Beware of sharp edges; use protective gloves when handling such assemblies.

**Flying leads:** Ensure that flying or loose leads are suitably restrained, to prevent snagging or entanglement, before carrying motors with such leads.

**Generation:** If the motor is driven mechanically, it may generate hazardous voltages at its power input terminals. The power connector must be suitably guarded to prevent a possible shock hazard.

**Loose motors:** When running an unmounted motor, ensure that the rotating shaft is adequately guarded and the motor is physically restrained to prevent it from moving. Remove the key which otherwise could fly out when the motor is running.

**Damaged cables:** Damage to cables or connectors may cause an electrical hazard. Ensure there is no damage before energizing the system.

**Supply:** Servo motors must not be directly connected to a power supply; they require an electronic drive system. Consult the instructions for the drive system before energizing or using the motor.

**Brakes:** The brakes that are included on motors are holding brakes only and are not to be used as a mechanical restraining device for safety purposes.

**Safety requirements:** The safe incorporation of this product into a machine system is the responsibility of the machine designer, who should comply with the local safety requirements at the place where the machine is to be used. In Europe this is likely to be the Machinery Directive.

**Mechanical connection:** Motors must be connected to the machine with a torsionally rigid coupler or a reinforced timing belt. Couplers which are not rigid will cause difficulty in achieving an acceptable response from the control system. Couplings and pulleys must be tight as the high dynamic performance of a servo motor can easily cause couplings to slip, and thereby damage the shaft and cause instability. Care must be taken in aligning couplings and tightening belts so that the motor is not subjected to significant bearing loads, or premature bearing wear will occur. Once connected to a load, tuning will be affected. A system tuned without a load will probably require retuning once a load is applied.

**Connectors:** Motor power connectors are for assembly purposes only. They should not be connected or disconnected while power is applied.

# Motor Installation

Observe the following installation guidelines and those in the Product Notice:

## WARNING

**MOTORS CAN CAUSE EXTENSIVE DAMAGE AND INJURY IF MOUNTED IMPROPERLY.**

1. Do not run motors that are not properly mounted. Attach all power and data cables after the motor is mounted.
2. Mount motors with connectors pointing downward and use a drip loop in the cable to keep liquids flowing away from the connectors.
3. Consider motor case temperature if necessary to safeguard operator and maintenance staff. Maximum case temperature is approximately 100°C (212°F) for a motor used at continuous rating in a 40°C ambient temperature.
4. The installer must comply with all local regulations and should use equipment and installation practices that promote electromagnetic compatibility and safety.

## Preventing Electrical Noise

ElectroMagnetic Interference (EMI), commonly called “noise”, may adversely impact motor performance by inducing stray signals. Effective techniques to counter EMI include filtering the AC power, shielding and separating signal carrying lines, and practicing good grounding techniques. Effective AC power filtering can be achieved through the use of isolated AC power transformers or properly installed AC line filters. Physically separate signal lines from motor cabling and power wiring; do *not* parallel signal wires with motor or power wires or route signal wires over the vent openings of servo drives. Ground all equipment using a single-point parallel ground system that employs ground bus bars or straps. If necessary, use electrical noise remediation techniques to mitigate EMI in “noisy” environments.

Knowledgeable cable routing and careful cable construction improves system electromagnetic compatibility (EMC). General cable build and installation guidelines include:

1. Keep wire lengths as short as physically possible.
2. Route signal cables (encoder, serial, analog) away from motor and power wiring.
3. Separate cables by 1 foot minimum for every 30 feet of parallel run.
4. Ground both ends of the encoder cable and twist the signal wire pairs.
5. Use shielded motor cables when necessary to prevent electromagnetic interference (EMI) with other equipment.

## Couplings and Pulleys

Mechanical connections to the motor shaft, such as couplings and pulleys, require a rigid coupling or a reinforced timing belt. The high dynamic performance of servo motors can cause couplings, pulleys or belts to loosen or slip over time. A loose or slipping connection will cause system instability and may damage the motor shaft and keyway. All connections between the system and the servo motor shaft must be rigid to achieve acceptable response from the system. Connections should be periodically inspected to verify the rigidity.

When mounting couplings or pulleys to the motor shaft, ensure that the connections are properly aligned and that axial and radial loads are within the specifications of the motor. The section Motor Radial Load Force Ratings provide guidelines to achieve 20,000 hours of bearing life. Additional information about load force ratings, including graphical depiction of varied load ratings and bearing life, is available for any motor from the Technical Support groups listed on the back cover.

# Motor Radial Load Force Ratings

Motors are capable of carrying an axial load in most applications. The following table provides guidelines for 20,000 hour bearing life with a specified radial load applied to the center of the shaft. Please consult with Giddings & Lewis regarding loads, operating speeds and bearing life in your particular application to ensure the proper selection of motors.

STANDARD RADIAL LOAD FORCE RATINGS							
MOTOR	500 rpm lb (kg)	1000 rpm lb (kg)	2000 rpm lb (kg)	3000 rpm lb (kg)	4000 rpm lb (kg)	5000 rpm lb (kg)	6000 rpm lb (kg)
HSM205	105 (63.5)	84 (50.8)	66 (39.9)	58 (34.9)	53 (31.8)	49 (29.5)	45 (20.4)
HSM307	113 (68.0)	90 (54.4)	71 (43.1)	62 (37.6)	56 (34.0)	53 (31.8)	
HSM320	126 (76.2)	101 (60.8)	79 (47.6)	69 (41.7)	63 (38.1)	59 (35.4)	
HSM430	169 (102.1)	152 (91.6)	120 (72.6)	105 (63.5)	95 (57.6)		
HSM460	205 (123.8)	164 (98.9)	129 (78.0)	113 (68.0)	103 (62.1)		
HSM490	215 (129.7)	173 (104.3)	137 (82.6)	118 (71.2)	108 (65.3)		
HSM610	435 (263.1)	345 (208.7)	274 (165.6)	240 (145.2)			
HSM620	469 (283.5)	375 (226.8)	296 (179.2)	259 (156.5)			
HSM630	495 (299.4)	390 (235.9)	311 (188.2)	270 (163.3)			
HSM835	495 (299.4)	394 (238.1)	311 (188.2)				
HSM845	518 (313.0)	413 (249.5)	326 (197.3)				

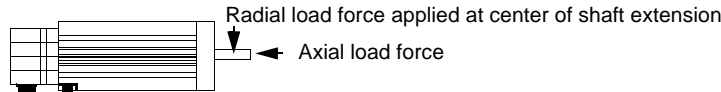

NOTE: When motor shaft has no radial load, axial load rating = 100% of radial load rating above.  
When motor shaft has both a radial load and an axial load, axial load rating = 44% of radial load rating above.

# Brake Motor Application Guidelines

## Brake Motors

The brakes offered as options on these servo motors are holding brakes. They are designed to hold the motor shaft at 0 rpm for up to the rated brake holding torque. The brakes are spring-set type, and release when voltage is applied to the brake coil.

The brakes are *not* designed for stopping rotation of the motor shaft. Servo drive inputs should be used to stop motor shaft rotation. The recommended method of stopping motor shaft rotation is to command the servo drive to decelerate the motor to 0 rpm, and engage the brake after the servo drive has decelerated the motor to 0 rpm.

If system main power fails, the brakes can withstand use as stopping brakes. However, use of the brakes as stopping brakes creates rotational mechanical backlash that is potentially damaging to the system, increases brake pad wear and reduces brake life. The brakes are *not* designed nor are they intended to be used as a safety device.

A separate power source is required to disengage the brake. This power source may be controlled by the servo motor controls, in addition to manual operator controls.

## Brake Specifications

BRAKE DATA					
MOTOR SERIES	MAX. BACKLASH (BRAKE ENGAGED)	HOLDING TORQUE		COIL CURRENT	
		(lb/in)	(Nm)	at 24 VDC	at 90 VDC
HSM3xx	1 degree, 30 minutes	20	2.26	0.50 ADC	0.13 ADC
HSM4xx	44 minutes	90	10.2	0.69 ADC	0.20 ADC
HSM6xx	29 minutes	275	31.1	1.30 ADC	0.48 ADC
HSM8xx	21 minutes	450	50.8	2.00 ADC	0.75 ADC

# Motor Data

MOTOR MODEL		HSM205	HSM307	HSM320	HSM430	HSM460
MECHANICAL DATA (1)						
Rotor Moment of Inertia	kg-m <sup>2</sup>	0.000015	0.000030	0.000080	0.00025	0.00046
	lb-in-s <sup>2</sup>	0.00013	0.00027	0.00072	0.0022	0.0041
Brake Motors Rotor Moment of Inertia	kg-m <sup>2</sup>	-	0.000038	0.000089	0.00033	0.00054
	lb-in-s <sup>2</sup>	-	0.00034	0.00079	0.0029	0.0048
Motor Weight: Net	kg/lb	2.2/4.9	2.6/5.8	4.1/9.0	6.8/14.9	9.7/21.4
	Shipping	kg/lb	2.7/6.0	3.2/7.0	4.7/10.4	7.3/16.1
Brake Motor Weight: Net	kg/lb	-	3.4/7.5	4.9/10.8	8.8/19.4	11.8/26.0
	Shipping	kg/lb	-	3.8/8.4	5.5/12.1	9.4/20.7
Damping	Nm/krpm	0.007	0.010	0.014	0.034	0.045
	lb-in/krpm	0.06	0.09	0.12	0.30	0.40
Friction Torque	Nm	0.014	0.014	0.028	0.034	0.068
	lb-in	0.12	0.12	0.25	0.30	0.60
Max. Operating Speed	rpm	6000	5000	5000	4000	4000
WINDING DATA (1)						
Poles		4	6	6	6	6
Sine Wave K <sub>T</sub> Torque Constant (2)	Nm/A	0.13	0.28	0.28	0.50	0.50
	lb-in/A	1.17	2.5	2.5	4.4	4.4
Square Wave K <sub>T</sub> Torque Constant (3)	Nm/A	0.14	0.31	0.31	0.54	0.54
	lb-in/A	1.3	2.7	2.7	4.8	4.8
K <sub>E</sub> Voltage Constant (4)	V/krpm	16	34	34	60	60
Winding Resistance Phase to Phase at 25°C	Ohms ±10%	2.6	6.6	1.3	2.0	0.69
Winding Inductance Phase to Phase	mH	4.1	12	3.4	9.0	3.3
Thermal Resistance	°C/Watt	1.45	1.2	0.89	0.79	0.57
Dielectric Rating		Power Leads (R, S, T) to Ground: 1500 VACrms 50/60 Hz for 1 minute.				

MOTOR MODEL		HSM490	HSM610	HSM620	HSM630	HSM835	HSM845
MECHANICAL DATA (1)							
Rotor Moment of Inertia	kg-m <sup>2</sup>	0.00068	0.0014	0.0024	0.0034	0.0063	0.0094
	lb-in-s <sup>2</sup>	0.0060	0.012	0.021	0.030	0.056	0.083
Brake Motors Rotor Moment of Inertia	kg-m <sup>2</sup>	0.00076	0.0017	0.0027	0.0037	0.0093	0.012
	lb-in-s <sup>2</sup>	0.0067	0.015	0.024	0.033	0.082	0.109
Motor Weight: Net	kg/lb	12.9/28.4	18.3/40.4	27.0/59.4	34.8/76.8	44.1/97	58.1/128
	Shipping	kg/lb	14.1/31.1	19.2/42.3	28.6/63.0	37.7/83.1	46.8/103
Brake Motor Weight: Net	kg/lb	14.9/32.8	22.5/49.5	31.6/69.5	39.2/86.4	50.9/112	61.8/136
	Shipping	kg/lb	16.0/35.3	23.8/52.5	32.9/72.5	42.2/93.0	53.5/118
Damping	Nm/krpm	0.068	0.10	0.16	0.19	0.38	0.43
	lb-in/krpm	0.60	.90	1.4	1.7	3.4	3.8
Friction Torque	Nm	0.14	0.14	0.24	0.36	0.32	0.40
	lb-in	1.2	1.2	2.1	3.2	2.8	3.5
Max. Operating Speed	rpm	3000	3000	3000	3000	2000	2000
WINDING DATA (1)							
Poles		6	8	8	8	8	8
Sine Wave K <sub>T</sub> Torque Constant (2)	Nm/A	0.74	0.68	0.66	0.70	0.86	0.92
	lb-in/A	6.6	6.0	5.8	6.2	7.6	8.2
Square Wave K <sub>T</sub> Torque Constant (3)	Nm/A	0.81	0.74	0.72	0.77	0.94	1.0
	lb-in/A	7.2	6.6	6.4	6.8	8.3	9.0
K <sub>E</sub> Voltage Constant (4)	V/krpm	90	82	80	85	104	112
Winding Resistance Phase to Phase at 25°C	Ohms ±10%	0.90	0.49	0.18	0.12	0.13	0.10
Winding Inductance Phase to Phase	mH	5.4	4.4	2.2	1.2	2.5	2.4
Thermal Resistance	°C/Watt	0.48	0.34	0.31	0.24	0.23	0.21
Dielectric Rating		Power Leads (R, S, T) to Ground: 1500 VACrms 50/60 Hz for 1 minute.					

(1) Specifications are at 25°C unless otherwise noted.

(3) Peak value of per phase square wave Amperes

(2) Peak value of per phase sine wave Amperes

(4) Peak value of sinusoidal phase to phase Volts

## STORAGE AND OPERATING CONDITIONS

Ambient Temperature: Operating	0 to 40°C (32 to 104°F)	Relative Humidity:	5% to 95%
Storage	-30 to 70°C (-25 to 158°F)		non-condensing

## Connector Data

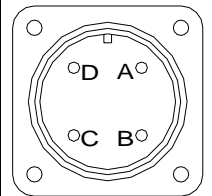
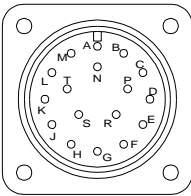
All HSM-Series Encoder		Torque Specifications		All HSM-Series Power			
Pin	Signal	Connector	Range (lb-in)	Pin	Signal		
A	A+	POWER		A	R		
B	A-	HSM2xx and HSM3xx	70 - 75	B	S		
C	B+	HSM4xx	80 - 85	C	T		
D	B-	HSM6xx	100 - 110	D	MOTOR CASE		
E	I+	HSM8xx	150 - 160				
F	I-	FEEDBACK					
G	ENCODER CASE	All HSM Series	80 - 85				
H	ABS	BRAKE					
J	+5VDC	All HSM Series	34 - 40				
K	+5VDC	NOTE: These connector torque specifications achieve a positive seal of the O-ring necessary for an IP65 rating.					
L	COM						
M	COM						
N	HALL B						
P	HALL C						
R	TS+						
S	TS-						
T	HALL A						
MIL-SPEC part numbers				MIL-SPEC part numbers		MIL-SPEC part numbers	
HSM2xx Encoder MS3102R20-29P				HSM2xx Power MS3102R18-4P		All HSM Series	
HSM3xx Encoder MS3102R20-29P				HSM3xx Power MS3102R18-4P		Brake MS-3102R12S-3P	
HSM4xx Encoder MS3102R20-29P		HSM4xx Power MS3102R20-4P					
HSM6xx Encoder MS3102R20-29P		HSM6xx Power MS3102R24-22P					
HSM8xx Encoder MS3102R20-29P		HSM8xx Power MS3102R32-17P					

## Encoder Data

Encoders are factory aligned and must not be adjusted outside the factory.



ENCODER SPECIFICATIONS	
Line Count	2000 (1)
Supply Voltage	5 VDC
Supply Current	250 mA max.
Line Driver	26LS31
Line Driver Output	TTL
Index Pulse	HSM2xx and HSM3xx Series when key faces 180°±10 away from the connectors HSM4xx, HSM6xx and HSM8xx Series when key faces the connectors (0°±10)

(1) Standard line count before quadrature

## Options: Connectors and Shaft Seals

An IP65 package may be formed when an HSM Series motor is coupled with environmentally sealed Military Specification (MS) cable assemblies and optional shaft seals. Equipment rated as IP65 provides protection against the ingress of dust and water projected by a nozzle (jet) from any direction. An IP65 rating is roughly equivalent to a NEMA 12 enclosure type rating. Always mount motors so the connectors project down.

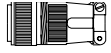
## MS Connector Kits

MOTOR POWER CONNECTORS				
	STRAIGHT	MOTOR SERIES	RIGHT ANGLE	
	M.1015.7798 (Legacy No. 401-34269-00) (MS3106F18-4S)	HSM2xx and HSM3xx	M.1015.7799 (Legacy No. 401-34269-00) (MS3108F18-4S)	
	M.1015.7801 (Legacy No. 401-34270-00) (MS3106F20-4S)	HSM4xx	M.1015.7802 (Legacy No. 401-34270-90) (MS3108F20-4S)	
	M.1015.7804 (Legacy No. 401-34271-90) (MS3106F24-22S)	HSM6xx	M.1015.7805 (Legacy No. 401-34271-90) (MS3108F24-22S)	
	M.1015.7807 (Legacy No. 401-34272-00) (MS3106F32-17S)	HSM8xx	M.1300.3509 (Legacy No. 401-34273-00) (MS3108F32-17S)	

BRAKE POWER CONNECTORS	
STRAIGHT	RIGHT ANGLE
M.1015.7813 (Legacy No. 401-34276-00) (MS3106F12S-3S)	M.1015.7815 (Legacy No. 401-34276-90) (MS3108F12S-3S)

ENCODER FEEDBACK CONNECTORS	
STRAIGHT	RIGHT ANGLE
M.1015.7808 (Legacy No. 401-34273-00) (MS3106F20-29S)	M.1015.7809 (Legacy No. 401-34273-90) (MS3108F20-29S)

## Wire and Contact Sizing Recommendations

The following connector contact sizes and wiring gages are recommended for cabling to a motor.

POWER CONNECTOR		
MOTOR	CONTACT AWG(mm <sup>2</sup> )	WIRE AWG(mm <sup>2</sup> )
HSM205	16 (1.5)	16 (1.5)
HSM307	16 (1.5)	16 (1.5)
HSM320	16 (1.5)	16 (1.5)
HSM430	12 (4.0)	16 (1.5)
HSM460	12 (4.0)	14 (2.5)
HSM490	12 (4.0)	14 (2.5)
HSM610	8 (8.6)	12 (4.0)
HSM620	8 (8.6)	8 (10)
HSM630	8 (8.6)	8 (10)
HSM835	4 (21.6)	6 (16)
HSM850	4 (21.6)	6 (16)

Sizes are recommended minimum values for 4 conductors (R, S, T and GND). Wiring should be twisted. Local regulations should always be observed.

ENCODER CONNECTOR	
CONTACT AWG(mm <sup>2</sup> )	WIRE AWG(mm <sup>2</sup> )
16 (1.5) for all HSM Series	24 (0.25) with DSA Drives
	22 (0.34) with DSA Drives
	22 (0.34) with DSA Drives

BRAKE CONNECTOR	
CONTACT AWG(mm <sup>2</sup> )	WIRE AWG(mm <sup>2</sup> )
16 (1.5)	18 (0.75)
Recommended minimum mechanical size. Local regulations should always be observed.	

Factory manufactured power cables and encoder cables are available in standard cable lengths of 10, 25, 50 and 75 feet (3, 7.6, 15 and 23 meters).

## Encoder Outputs

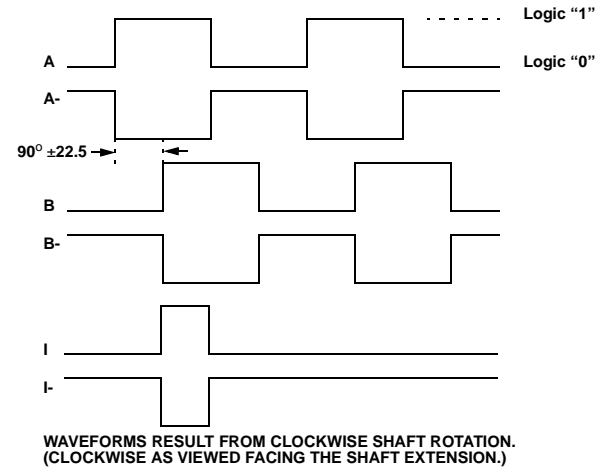

## Encoder Phase-to-Neutral and Phase-to-Phase Waveforms

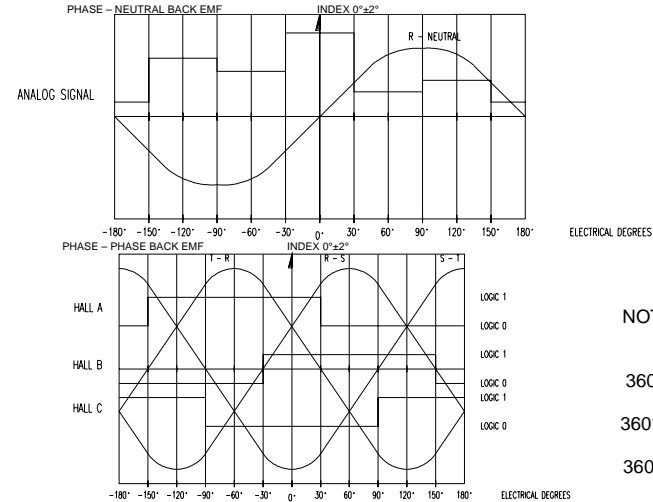

## Shaft Seal Kits

MOTOR SEAL KITS		
MOTOR SERIES	PART NUMBER	SIZE (Outside Dia x Inside Dia x Width)
HSM2xx	M.1300.3484 (Legacy No. 401-30225-00)	22mm x 12mm x 7mm (0.87" x 0.47" x 0.27")
HSM3xx	M.1007.0803 (Legacy No. 401-30226-00)	35mm x 15mm x 7mm (1.40" x 0.59" x 0.27")
HSM4xx	M.1015.6923 (Legacy No. 401-30227-00)	47mm x 20mm x 7mm (1.85" x 0.79" x 0.27")
HSM6xx	M.1015.6924 (Legacy No. 401-30228-00)	80mm x 38mm x 8mm (3.15" x 1.50" x 0.31")
HSM8xx	M.1300.3485 (Legacy No. 401-30229-00)	85mm x 45mm x 8mm (3.35" x 1.77" x 0.31")

NOTE: Shaft seals are manufactured to millimeter dimensions. Inch dimensions are conversions from millimeters. Shaft seals require a lubricant to reduce wear. Lubricant is provided with kit.

# HSM4xx Series NEMA 56C Motors

	Without Brake	With Brake
Motors	in/mm	in/mm
HSM430 NEMA 56C	8.39/213	10.47/266
HSM460 NEMA 56C	10.39/264	12.48/317
HSM490 NEMA 56C	12.40/315	14.49/368

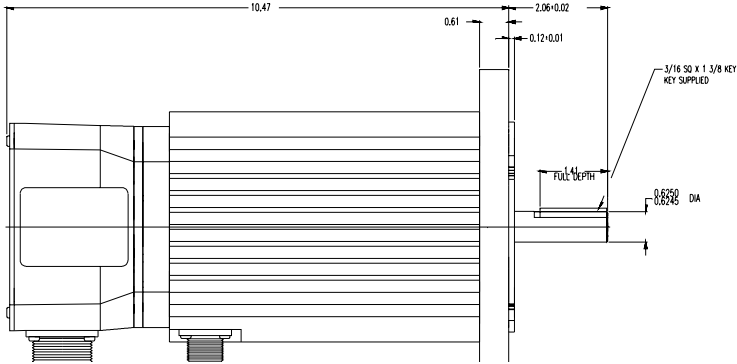

**SUPPLEMENTAL NEMA56C MOTOR DIMENSIONS  
LENGTH FROM MOTOR FACEPLATE  
TO CENTER OF CONNECTORS**

Motors	BRAKE (in/mm)	POWER (in/mm)	ENCODER (in/mm)
HSM430	—	7.24/184	7.24/184
HSM430 BRAKE	6.30/160	9.29/236	9.29/236
HSM460	—	9.25/235	9.25/235
HSM460 BRAKE	8.31/211	11.30/287	11.30/287
HSM490	—	11.26/286	11.26/286
HSM490 BRAKE	10.31/262	13.30/338	13.30/338

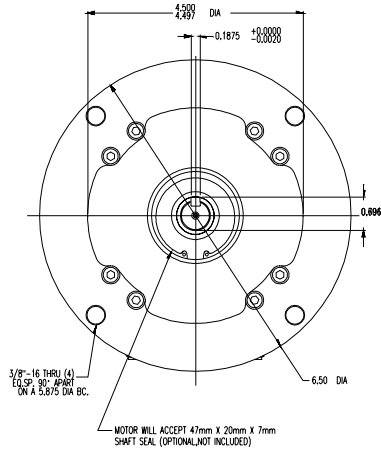

NOTE: NEMA 56C motors are manufactured to inch dimensions. Millimeter dimensions are approximate conversions from inches. Engineering specifications showing motor detail are available upon request.

# Dimensional Data

MOTOR DIMENSIONS																	NOTES (mm/in)
MOTOR MODEL	AB mm/in	AH mm/in	AJ mm/in	AK mm/in	BB mm/in	BE mm/in	BF mm/in	EP mm/in	L mm/in	L Brake mm/in	P mm/in	PF mm/in	S mm/in	U mm/in	XD mm/in		
HSM205	75/2.95	23/0.90 (3)	75/2.95	60/2.36 (1)	2.4/0.09 (4)	15.2/60	5.8/2.3	12/0.47	197/7.7	—	80/3.15	87/3.45	4x4/.16x.16	11/0.43 (2)	18/0.71	(1) Tolerance is -0.03/-0.0012	
HSM307	75/2.95	30/1.18 (3)	100/3.94	80/3.15 (1)	3/1.2 (4)	10.9/43	7/28	15/0.59	172/6.77	211/8.31	89/3.50	—	5x5/.20x.20	14/0.55 (2)	20/0.79	(2) Tolerance is - 0.01/-0.0004	
HSM320	75/2.95	30/1.18 (3)	100/3.94	80/3.15 (1)	3/1.2 (4)	10.9/43	7/28	15/0.59	223/8.77	262/10.31	89/3.50	—	5x5/.20x.20	14/0.55 (2)	20/0.79	(3) Tolerance is ±0.5/±0.0196	
HSM430	76/3.00	50/1.97 (3)	145/5.71	110/4.33 (5)	3/1.2 (4)	15.5/61	10/39	20/0.79	213/8.39	266/10.47	121/4.76	—	6x6/.24x.24	19/0.75 (6)	40/1.57	(4) Tolerance is ±0.2/±0.0079	
HSM460	76/3.00	50/1.97 (3)	145/5.71	110/4.33 (5)	3/1.2 (4)	15.5/61	10/39	20/0.79	264/10.39	317/12.48	121/4.76	—	6x6/.24x.24	19/0.75 (6)	40/1.57	(5) Tolerance is - 0.035/-0.0014	
HSM490	76/3.00	50/1.97 (3)	145/5.71	110/4.33 (5)	3/1.2 (4)	15.5/61	10/39	20/0.79	315/12.40	368/14.49	121/4.76	—	6x6/.24x.24	19/0.75 (6)	40/1.57	(6) Tolerance is -0.013/-0.0051	
HSM610	101/4.00	80/3.15 (3)	200/7.87	114.3/4.50 (5)	4/1.6 (4)	21.3/84	13.5/53	38/1.50	277/10.91	330/12.99	178/7.01	—	10x8/.39x.31	35/1.38 (7)	60/2.36	(7) Tolerance is - 0.16/-0.006	
HSM620	101/4.00	80/3.15 (3)	200/7.87	114.3/4.50 (5)	4/1.6 (4)	21.3/84	13.5/53	38/1.50	353/13.90	406/15.98	178/7.01	—	10x8/.39x.31	35/1.38 (7)	60/2.36	(8) Tolerance is - 0.46/-0.0181	
HSM630	101/4.00	80/3.15 (3)	200/7.87	114.3/4.50 (5)	4/1.6 (4)	21.3/84	13.5/53	38/1.50	429/16.89	482/17.40	178/7.01	—	10x8/.39x.31	35/1.38 (7)	60/2.36		
HSM835	112/4/41	85/3.35 (3)	265/10.43	230/9.06 (8)	4/1.6 (4)	22.4/88	15/59	45/1.77	375/14.76	478/18.82	241/9.49	—	12x8/.47x.31	42/1.65 (7)	60/2.36		
HSM850	112/4/41	85/3.35 (3)	265/10.43	230/9.06 (8)	4/1.6 (4)	22.4/88	15/59	45/1.77	426/16.77	529/20.83	241/9.49	—	12x8/.47x.31	42/1.65 (7)	60/2.36		

Motors are manufactured to millimeter dimensions. Inch dimensions are approximate conversions from millimeters.

SUPPLEMENTAL MOTOR DIMENSIONS - LENGTH FROM MOTOR FACEPLATE TO CENTER OF CONNECTORS																					
CONNECTOR	HSM205	HSM307	BRAKE	HSM320	BRAKE	HSM430	BRAKE	HSM460	BRAKE	HSM490	BRAKE	HSM610	BRAKE	HSM620	BRAKE	HSM630	BRAKE	HSM835	BRAKE	HSM845	BRAKE
BRAKE (mm/in)	—	—	107/4.21	—	158/6.22	—	160/6.30	—	211/8.31	—	262/10.31	—	189/7.44	—	265/10.43	—	341/13.42	—	334/13.13	—	384/15.13
POWER (mm/in)	167/6.58	143/5.63	181/7.13	194/7.64	232/9.13	184/7.24	236/9.29	235/9.25	287/11.30	286/11.26	338/13.30	251/9.88	299/11.77	327/12.87	375/14.76	403/15.87	451/17.75	326/12.83	429/16.83	377/14.83	480/18.83
ENCODER(mm/in)	167/6.58	143/5.63	181/7.13	194/7.64	232/9.13	184/7.24	236/9.29	235/9.25	287/11.30	286/11.26	338/13.30	251/9.88	299/11.77	327/12.87	375/14.76	403/15.87	451/17.75	326/12.83	429/16.83	377/14.83	480/18.83

SHAFT END PLAY UNDER LOAD		
Maximum End Play (All Motors)	Motor Series	Load (Kg/Lb)
Direction		
→ <b>A</b>	HSM2xx/HSM3xx	4.54/10.0
	HSM4xx	9.09/20.0
← <b>B</b>	HSM6xx/HSM8xx	22.7/50

NOTE: End play and load are measured in inches and pounds. Metric measurements are approximate conversions from inches and pounds.

SHAFT END THREADED HOLE		
Motor Series	Thread	Thread/Depth
HSM2xx	M3 x 0.5mm	10mm/.39 in
HSM3xx	M4 x 0.7mm	10mm/.39in
HSM4xx	M6 x 1.0mm	15mm/.59in
HSM6xx	M8 x 1.25mm	20mm/.79in
HSM8xx	M8 x 1.25mm	20mm/.79in

NOTE: Motors are manufactured to millimeter dimensions. Inch dimensions are approximate conversions from millimeters.

